

Part Number: PT929-24150

Kit Contents

Item #	Quantity Req.	Description
1	1	Applique, RR Bumper

Hardware Bag Contents

Item #	Quantity Req.	Description

Additional Items Required For Installation

Item #	Quantity Req.	Description

Conflicts

--

Recommended Tools

Personal & Vehicle Protection	Notes
None	
Special Tools	Notes
Squeegee	4" (3M™Gold) or 4" (3M™Silver)
Surface Thermometer	Infrared Non-contact
Low Friction Sleeve	3M SA-1 (OPTIONAL)
Heat Gun	Master Heat Gun HG-301A or equivalent
Installation Tools	Notes
Lint Free Cloths	
Spray Bottle	For wetting agent
Special Chemicals	Notes
Cleaner	VDC approved cleaner and cleaning method
Wetting Agent Note: Solution depends upon ambient temperature of the part and the vehicle surface. If it is difficult to remove bubbles with a squeegee, add one more ml. of shampoo.	Johnson's Baby Shampoo mixed in one liter of water: At 65°F add 2 ml. shampoo At 70°F add 3 ml. shampoo At 80°F add 3.5 ml shampoo At 90°F add 4 ml. shampoo

General Applicability

--

Recommended Sequence of Application

Item #	Accessory

*Mandatory

Vehicle Service Parts (may be required for reassembly)

Item #	Quantity Req.	Description

Legend

 **STOP:** Damage to the vehicle may occur. Do not proceed until process has been complied with.

 **OPERATOR SAFETY:** Use caution to avoid risk of injury.

 **CAUTION:** A process that must be carefully observed in order to reduce the risk of damage to the accessory/vehicle and to ensure a quality installation.

 **TOOLS & EQUIPMENT:** Used in Figures calls out the specific tools and equipment recommended for this process.

 **REVISION MARK:** This mark highlights a change in installation with respect to previous issue.

 **SAFETY TORQUE:** This mark indicates that torque is related to safety.

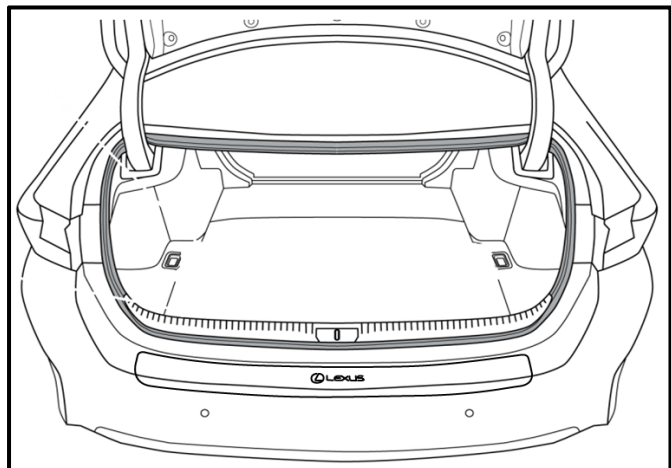





Care must be taken when installing this accessory to ensure damage does not occur to the vehicle. The installation of this accessory should follow approved guidelines to ensure a quality installation.

These guidelines can be found in the "Accessory Installation Practices" document.

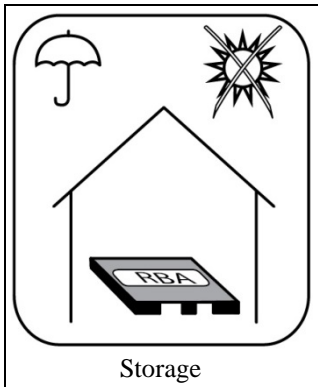
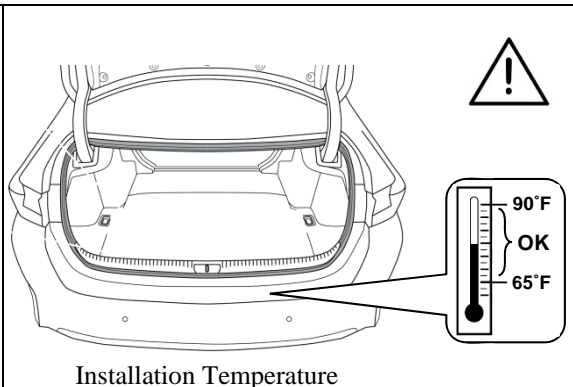
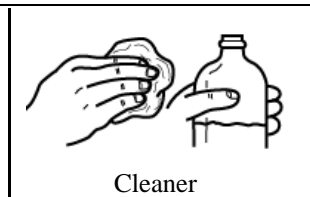
- This document covers such items as:-
- Vehicle Protection (use of covers and blankets, cleaning chemicals, etc.).
 - Safety (eye protection, rechecking torque procedure, etc.).
 - Vehicle Disassembly/Reassembly (panel removal, part storage, etc.).
 - Electrical Component Disassembly/Reassembly (battery disconnection, connector removal, etc.).

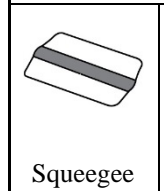
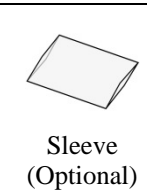
Please see your Lexus dealer for a copy of this document.

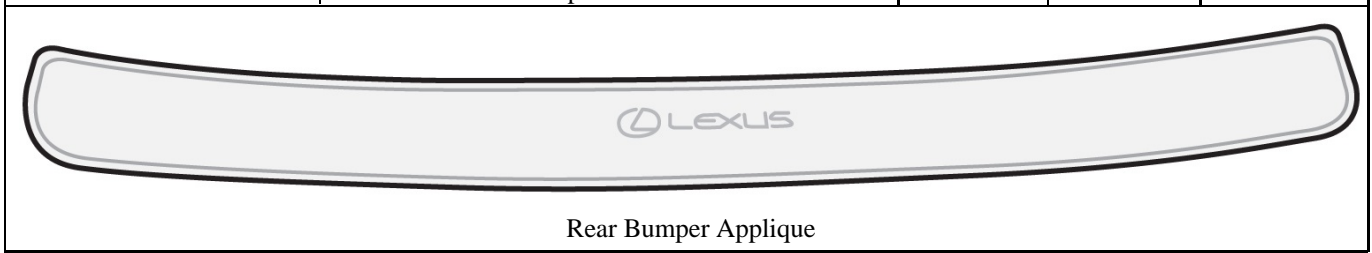
 <p>Storage</p>	 <p>Installation Temperature</p>	 <p>Cleaner</p>	
 <p>Squeegee</p>	 <p>Sleeve (Optional)</p>	 <p>Lint Free</p>	
 <p>Rear Bumper Applique</p>			

1

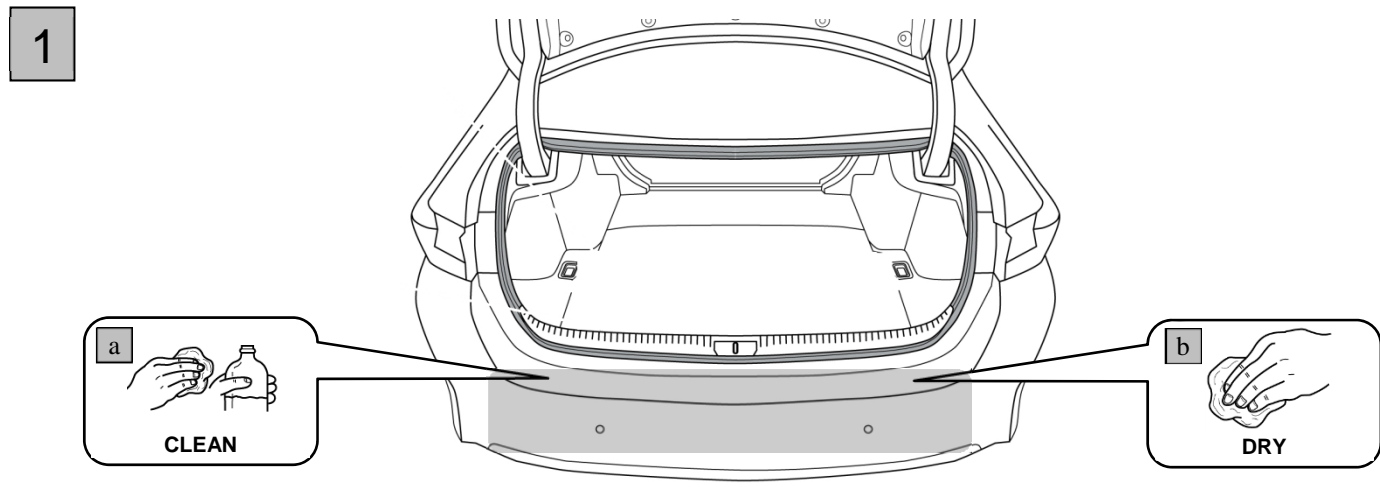

a CLEAN

b DRY

2

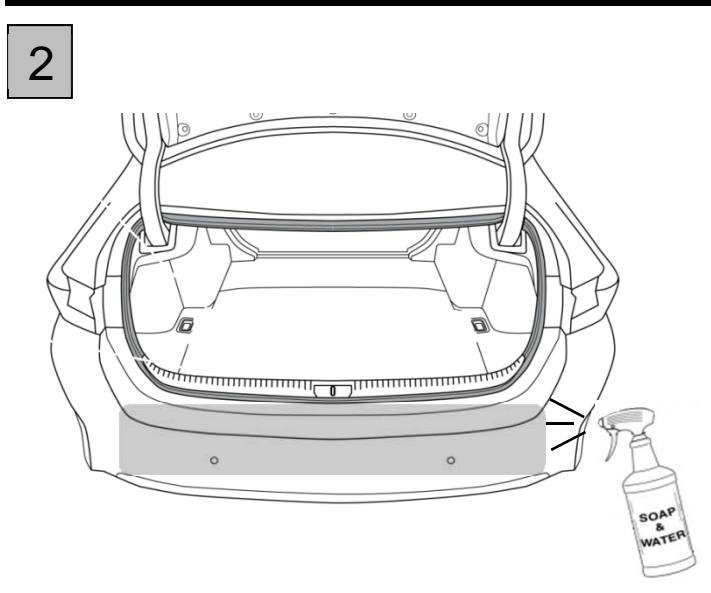

SOAP & WATER

3

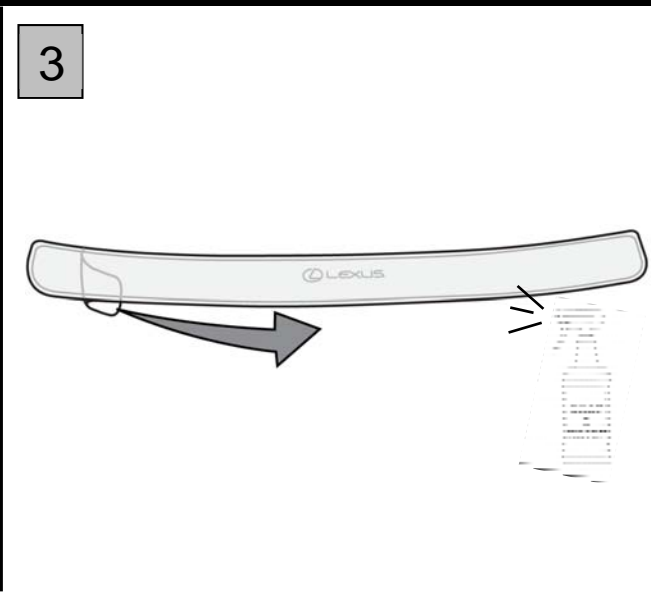

4

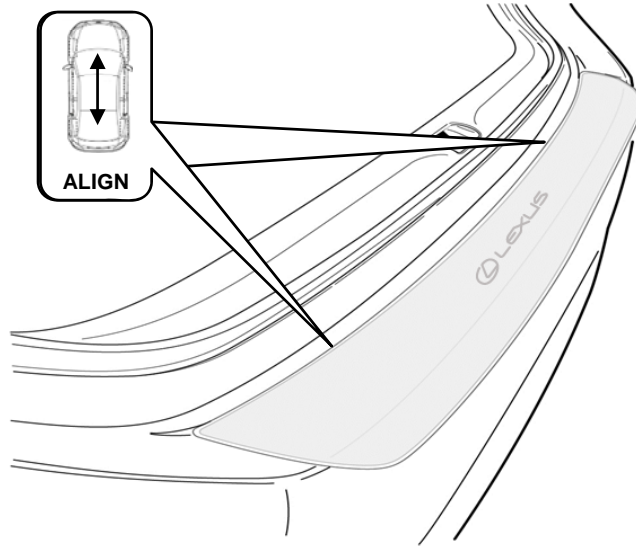

5

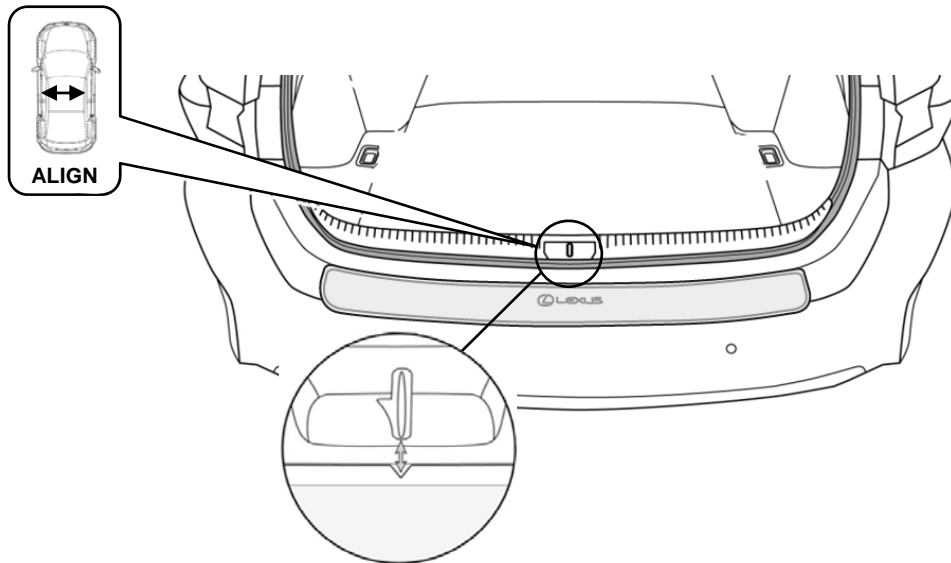

6

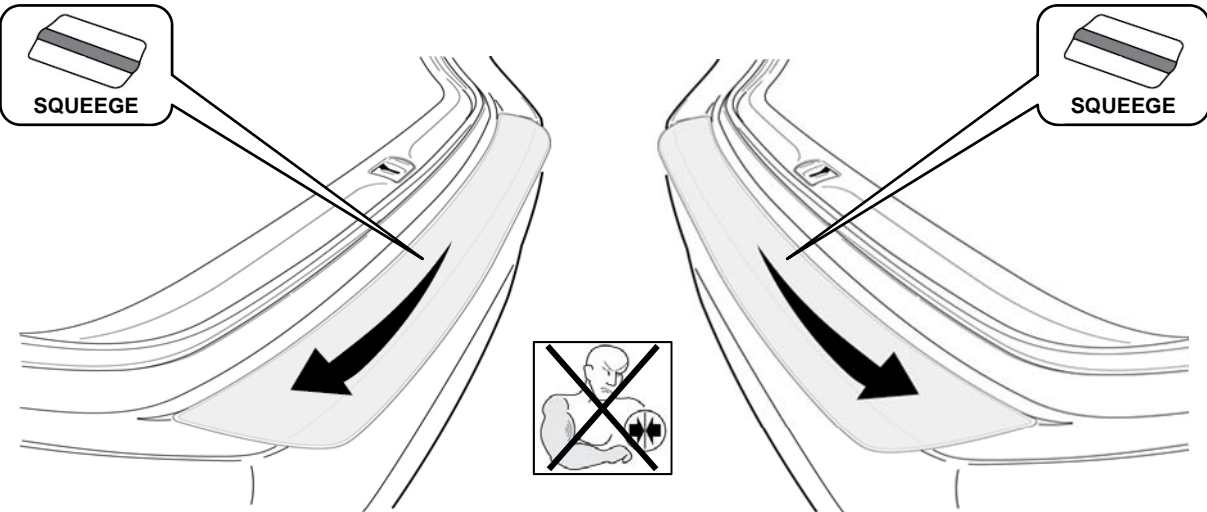

7

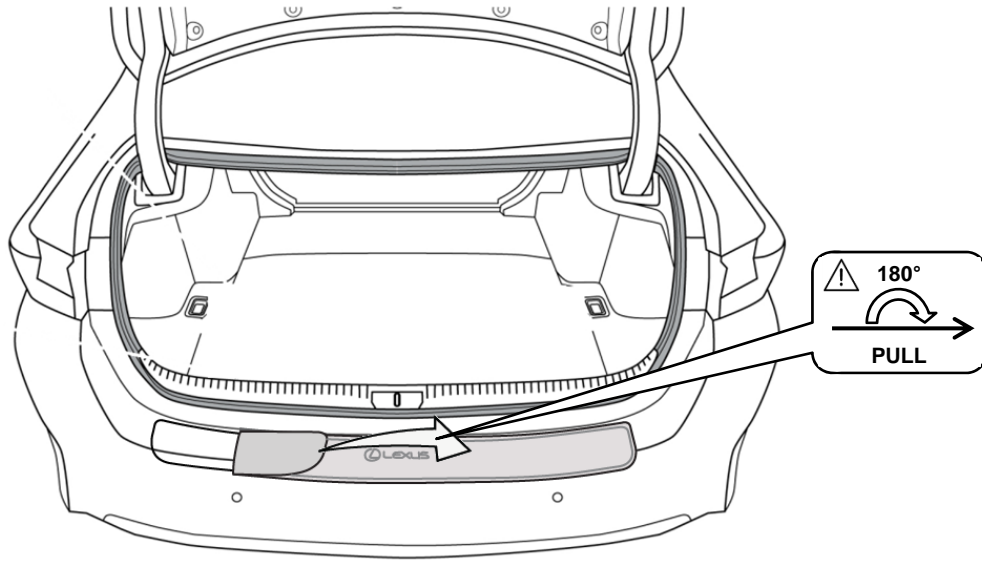

8

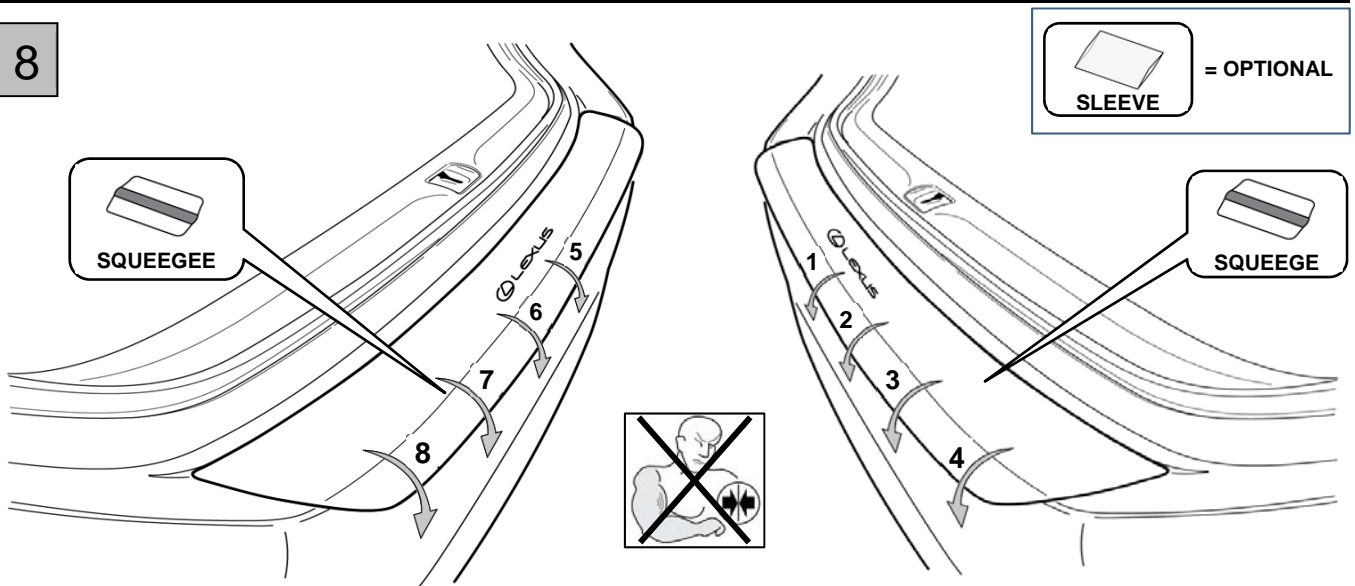

9

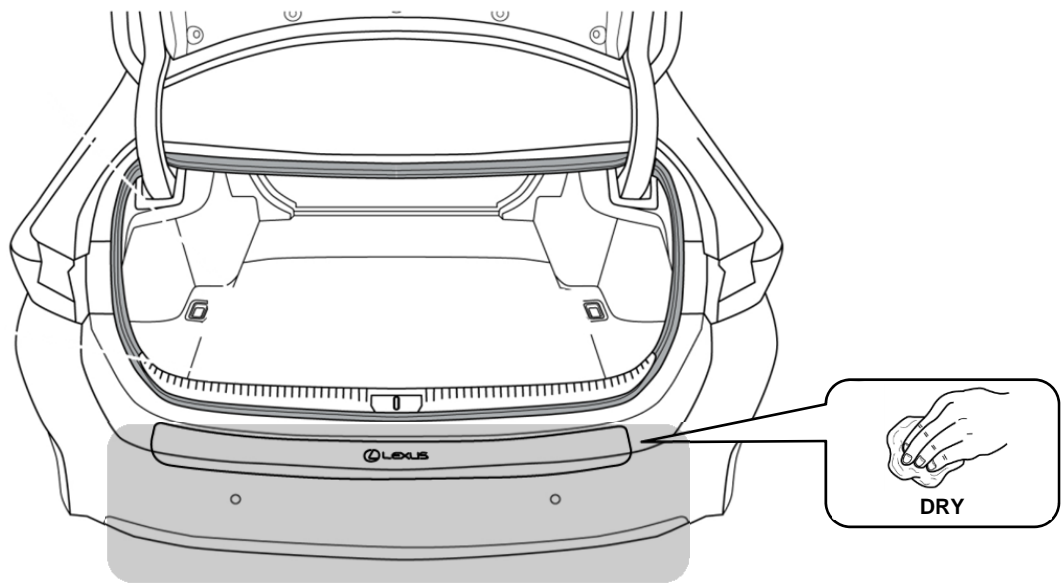

Checklist - these points **MUST** be checked to ensure a quality installation.

Check:

Look For:

Accessory Function Checks

- Proper adhesion – Visual
- Proper adhesion – Physical

- Proper alignment – Cross-Car

Look for bubbles, loose and lifting edges.

With light pressure rub hand over top of part and if crackling sound occurs, re-squeegee. If bubbles cannot be worked out to the nearest edge, replace part.

Part must be centered within bumper +/-3 mm.

Vehicle Appearance Check

- After accessory installation and removal of protective cover(s), perform a visual inspection.

Ensure no damage (including scuffs and scratches) was caused during the installation process.
(For PPO installations, refer to TMS Accessory Quality Shipping Standard.)